

SEISMIC DESIGN MEASURES FOR THE RETROFIT OF THE CLAREMONT TUNNEL

R. John Caulfield

Jacobs Associates

D. Scott Kieffer

Colorado School of Mines

David F. Tsztoo

East Bay Municipal Utility District

Bill Cain

East Bay Municipal Utility District

ABSTRACT

In 1994, the East Bay Municipal Utility District (EBMUD) commenced a system-wide Seismic Improvement Program to protect their facilities from catastrophic damage. A primary focus of this program has been on retrofitting the 75-year old Claremont Tunnel, which crosses the active Hayward Fault zone. A large earthquake on the Hayward Fault could generate enough right-lateral fault slip to effectively sever this important lifeline. The retrofit project involves construction of a new bypass tunnel through the Hayward Fault zone, together with systematic contact grouting and localized structural repair of the existing concrete liner. Several innovative design measures have been incorporated into the seismic retrofit design, including an oversized tunnel cross section, backfill concrete side drifts, seismic isolation of an internal structural pipe, and shear fuses in the final lining.

INTRODUCTION

The Claremont Tunnel was constructed from 1926 to 1929. It is a 2.74 m (9 foot) diameter, 5.5 km (18,065 foot) long horseshoe tunnel that carries treated water by gravity flow through the Berkeley Hills from the Orinda Water Treatment Plant to the Claremont Center in the East Bay region of the San Francisco Bay (refer to Figure 1). The final lining of the tunnel consists of primarily unreinforced concrete, with the exception of small, sporadic reaches of steel reinforced concrete.

The tunnel is a critical lifeline facility for the communities along the eastern margins of the San Francisco Bay Area. It routinely carries between 416,000 to 662,000 cubic meters per day (110 to 175 million gallons per day) to serve about 70 percent of EBMUD's 1.2 million customers.

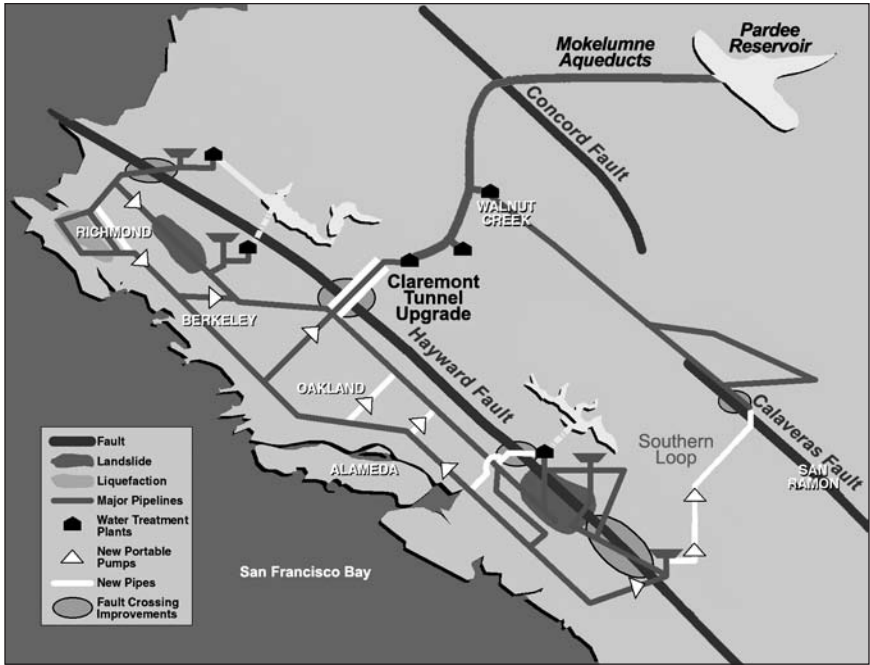

Figure 1. Schematic diagram of EBMUD's water distribution system and potential geologic hazards

The active Hayward Fault crosses the tunnel alignment, almost perpendicular to its axis, about 259 m (850 feet) from the west portal at the Claremont Center in Berkeley, California. The Hayward Fault last experienced a major seismic event that resulted in surface rupture in 1868. The U.S. Geological Survey Working Group on California Earthquake Probabilities has estimated that there is a 27 percent probability of a magnitude 6.7 or greater earthquake occurring on the Hayward Fault before the year 2032. EBMUD has adopted the magnitude 7.0 Maximum Credible Earthquake (MCE) along the Hayward Fault as the design event for the seismic upgrades. Geologists have estimated that the lateral offset from the MCE could be on the order of 2.3m (7.5 feet). This event would render the existing tunnel unserviceable.

PROJECT DEFINITION

In 1994, the EBMUD Board of Directors approved a \$189 million Seismic Improvement Program (SIP) to protect their water system from catastrophic seismic damage. Seismic upgrade of the Claremont Tunnel was identified as a key element of the program.

Following a major seismic event on the Hayward Fault, EBMUD's expects available labor and equipment resources to be fully utilized on emergency repairs of other parts of their distribution system and treatment plants. As a result, EBMUD required that the Claremont Tunnel seismic upgrades be designed to allow sustained operation for a period of 60 to 90 days following the earthquake.

Engineering studies showed the preferred solution for the seismic retrofit consisted of constructing a new 479 m (1571 foot) bypass tunnel through the Hayward

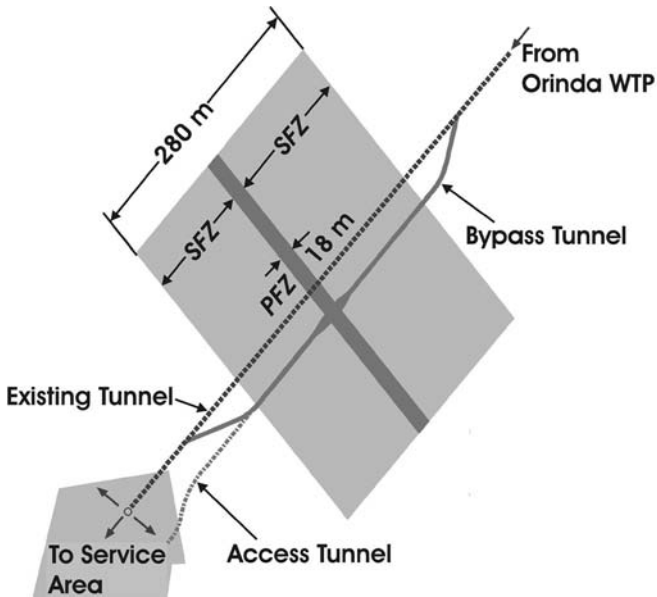

Figure 2. Schematic plan of the bypass tunnel layout with fault zones indicated (PFZ: Primary Fault Zone, SFZ: Secondary Fault Zone)

Fault zone, with a 146 m (480 foot) long access tunnel driven parallel to the existing tunnel. The bypass tunnel would tie into the existing Claremont Tunnel on either side of the Hayward Fault Zone (refer to Figure 2). This solution allows the majority of the construction to be performed while the existing tunnel remains in service. This was an important design constraint because outages of the tunnel are limited to wintertime construction windows of three months between December and February due to water system demands.

Construction of the bypass tunnel commenced in June 2004 and is expected to be completed in June 2006.

GEOLOGIC CONDITIONS

The geology along the proposed tunnel alignment is characterized by three reaches (refer to Figure 3). The westernmost reach, extending approximately 243m (800 feet) from the proposed tunnel portal, consists of mélangé of the Franciscan Complex. The mélangé is a chaotic mixture of sheared shale, sandstone, altered volcanic rocks, serpentinite, and occasional hard blocks of chert and blueschist. The rock quality is expected to vary considerably from crushed, soft and plastic in the shear zones to blocky, hard, and strong. Heavy, squeezing ground could be encountered in the sheared shale, serpentinite and within significant shear zones.

To the east, the next 232 m (760 foot) section along the alignment consists of materials altered by faulting. Detailed geologic logs and instrumentation of the Bay Area Rapid Transit (BART) tunnels, located approximately 243m (800 feet) southeast of the Claremont Tunnel, provided valuable information with respect to anticipated ground characteristics. The ground west of the primary fault zone is expected to be similar to the Franciscan Complex mélangé, with some clayey gouge zones. Within the

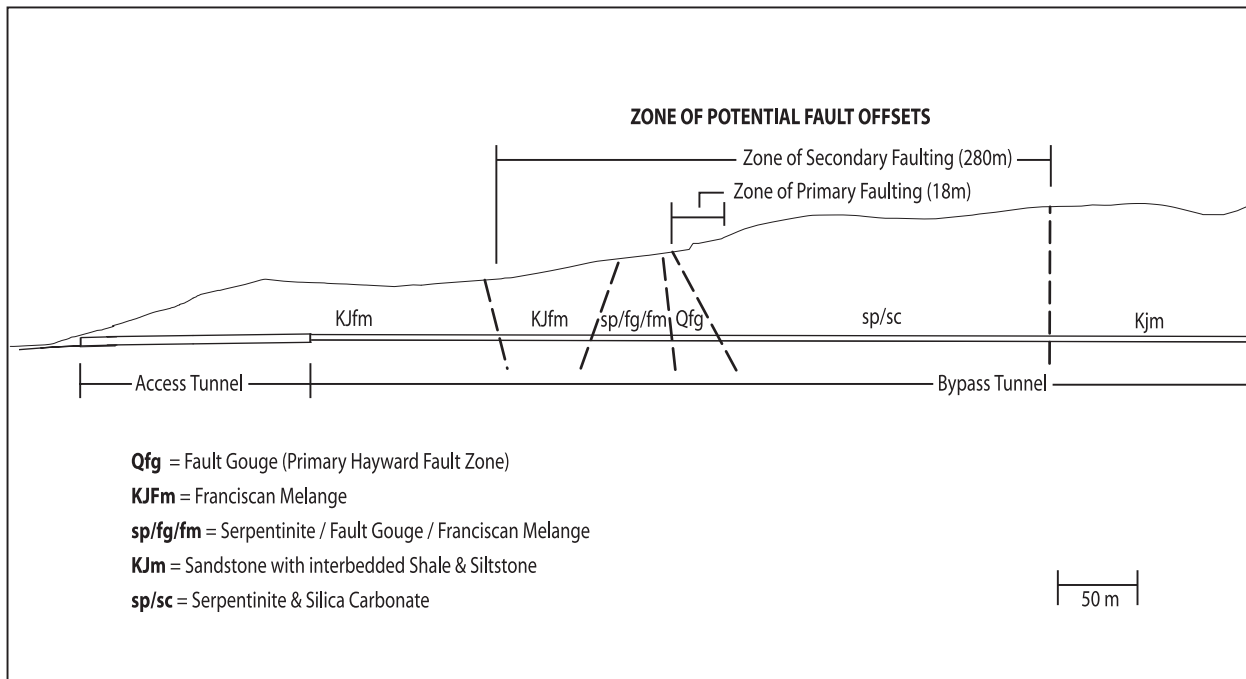

Figure 3. Geologic profile along the tunnel alignment

primary fault zone the rock quality is expected to consist of soft clay fault gouge with a consistency of a stiff to hard clay. To the east of the primary fault zone, the materials are expected to be primarily silica carbonate and serpentinite with some clayey gouge zones. The softer materials within this reach are expected to experience heavy squeezing.

The geologic unit at the easternmost reach of the bypass alignment, for a distance of approximately 104m (340 feet) consists of sandstone with interbedded shale and siltstone of the Great Valley Sequence. The sandstone is fine grained and moderately hard. It is anticipated to be primarily thinly bedded, with some thick beds of blocky rock. The shale beds are typically highly sheared and contorted. The bedding generally dips steeply to either the northeast or the southwest. Squeezing ground is expected within the soft, plastic zones of sheared siltstone and shale.

Naturally occurring methane gas and petroleum were encountered locally during mining of the original tunnel through the Great Valley Sequence, and the current bypass tunnel construction has been classified as "gassy" by the State of California Division of Occupational Safety and Health.

GROUNDWATER

Based upon readings from piezometers placed during field investigations in early 2001, the groundwater levels are expected to range between 1.8 to 12.2 m (6 to 40 feet) above the crown of the bypass tunnel. During a 2002 inspection of the Claremont Tunnel the cumulative groundwater inflow was measured at 22 liters per second (350 gallons per minute). Past inspections yielded similar inflows. This is much less than the flows encountered during the original construction in the 1920s, which reached a peak of 247 liters per second (3920 gallons per minute). It is believed that the existing Claremont Tunnel and the nearby Berkeley Hills BART Tunnels have acted as drains for groundwater along the alignment.

Based on this information, inflows of groundwater during construction into the bypass tunnel are not anticipated to be significant. Cumulative inflows into the bypass tunnel excavation to date, after approximately 500 feet of excavation, have been limited to less than 0.3 liters per second (5 gallons per minute).

FAULT CHARACTERIZATION

A critical part of the design process was the characterization of the potential fault movements and the development of design parameters. Project geologic studies estimated a primary fault displacement of 2.3 m (7.5 feet), with a 16 percent probability of exceedance, for a the design magnitude 7.0 earthquake on the Hayward Fault. The potential vertical offset was determined to be 0.23m (9 inches), which corresponds to approximately 10% of the potential horizontal offset. This movement was estimated to occur within an 18.3 m (60 foot) long section of the tunnel. This was established based on the past inspections and surveys of fault creep damage to the Claremont Tunnel and also through a careful review of historical records of the nearby Berkeley Hills BART tunnels.

The Hayward Fault is also actively creeping. Historically published rates of active fault creep along the fault in this area range from about 4.5mm to 6.4mm/year (0.18 to 0.25 inches per year). Survey measurements obtained from past Claremont Tunnel inspections confirmed these rates of movement. For the seismic upgrade of the Claremont Tunnel a design fault creep rate of 6mm per year (0.25 inches per year) and a total creep offset of 0.3m (1 foot) over a 50 year period was adopted.

Secondary faulting displacements, adjacent to the zone of primary displacement, were also a design consideration. The 18.3 m (60 foot) wide zone subject to primary fault offset is located within a 280 m (920 foot) wide zone that is susceptible to secondary fault offsets. The estimate of secondary fault displacements was approximately 30%, or 0.7 m (2.25 feet), of the primary fault offset. Secondary fault offsets were judged to potentially occur anywhere within the 280 m (920 foot) wide zone.

SEISMIC DESIGN MEASURES

The most challenging design issue for the upgrade project concerned developing a reliable scheme to provide uninterrupted operation of the tunnel following the design lateral and vertical offsets within the primary zone of faulting. The following discussion summarizes the design approach used to address the project objectives.

The primary design approach to accommodate fault offset of the tunnel structure was to create an enlarged opening through the zone subject to offset. By properly sizing the enlarged section to accommodate the expected offsets, local repairs, though potentially substantial, can be made following the earthquake event and the facility may be brought online in a timely manner.

While this enlarged opening approach alone may prove sufficient for many applications, it did not fulfil all of the design criteria established for the Claremont Tunnel upgrades. Since the Claremont Tunnel is a critical lifeline that carries treated water, it is important to minimize water flow impacts as much as possible until post-earthquake repairs can be implemented. It is expected that following a major seismic event, EBMUD's resources will be in high demand performing emergency repairs on other damaged facilities such as distribution pipelines and treatment plants. The Claremont Tunnel would have to convey essential water flows of at least 492,000 cubic meters per day (130 mgd) to meet minimal water requirements for a period of 60 to 90 days following the earthquake before EBMUD could undertake significant repairs to the tunnel.

Water quality was an important design consideration. An oversized tunnel can provide a proper post-earthquake cross section, but not mitigate the potential for faulted ground from entering and polluting the water supply. In order to minimize intrusion from faulted ground, the bypass tunnel includes backfill concrete side drifts through the zone subject to primary fault displacement. The side drifts, shown in Figures 4 and 5, have been dimensioned so there will be complete overlap of structural elements following the design lateral and vertical components of fault slip, thereby minimizing direct exposure of the faulted ground to flowing water within the tunnel. This will be important not only to reduce turbidity of the water, but also to reduce the chances for erosion around the outside perimeter of the lining, thereby further compromising the structural integrity of the already damaged lining system. The side drifts will be initially supported with fiberglass dowels and shotcrete reinforced with welded wire fabric. The dowels located between the side drifts will be effective in pre-supporting the face of the subsequent oversized tunnel excavation, which is expected to be driven through heavy squeezing ground, and the concrete backfill will provide needed bearing capacity for the oversized tunnel top heading loads.

During construction, the identification of the zone subject to primary fault displacement will be critical to the successful implementation of the design. Fortunately, the location of the primary zone of faulting is well constrained by creep damage to the existing Claremont and Bay Area Rapid Transit tunnel linings, located about 30 m (100 feet) to the northwest and 213 m (700 feet) to the southeast, respectively. Despite these constraints, the reliability of the upgraded facility will

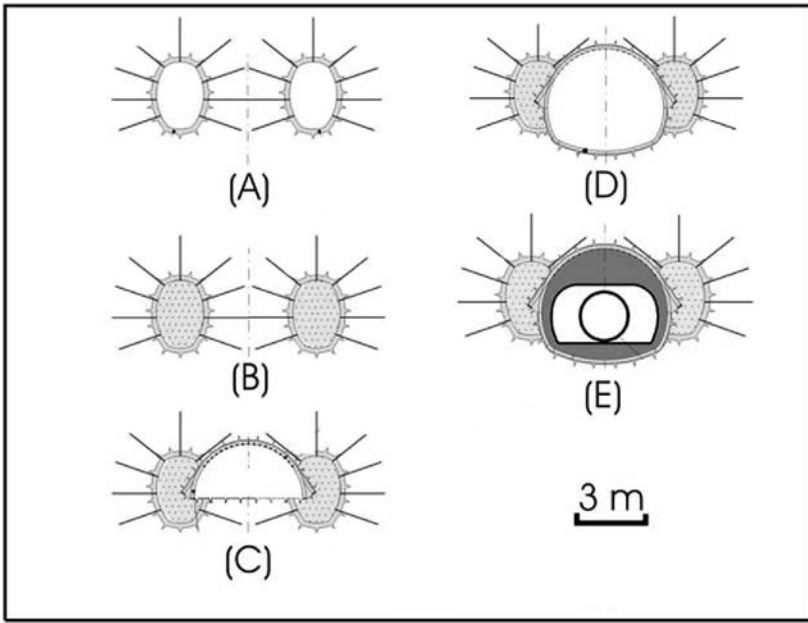

Figure 4. Cross section of oversized tunnel showing various construction stages: (A) excavation and support of side drifts; (B) placement of concrete backfill in side drifts; (C) excavation and support of top heading; (D) excavation of bench and ring closure; (E) placement of final concrete liner and structural carrier pipe

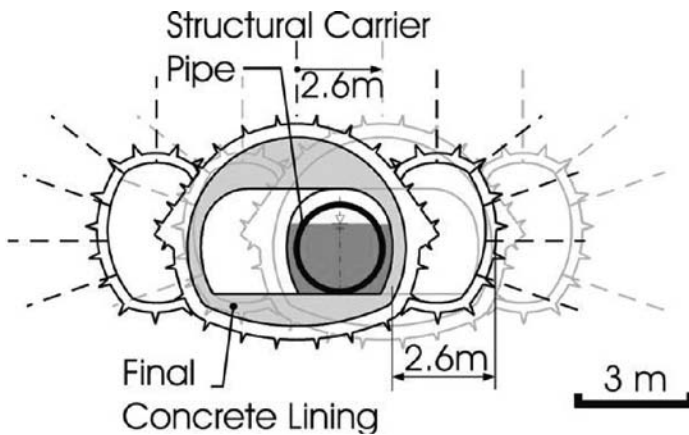

Figure 5. Cross section of oversized tunnel section after 2.6 m (8.5 feet) of discrete fault offset. Note that side drifts backfilled with concrete reduce the potential of faulted ground from entering tunnel.

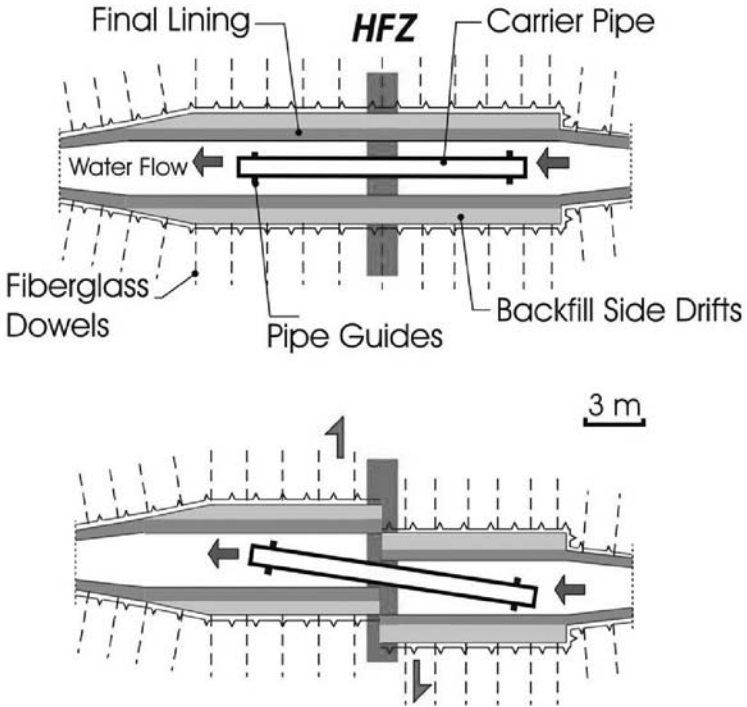

Figure 6. Plan view of oversized tunnel section showing configuration of structural carrier pipe before and after 2.6 m (8.5 feet) of discrete fault offset (HFZ: Hayward Fault Zone)

depend strongly on the quality of geologic characterization carried out in the bypass tunnel during construction. The first side drift will serve as a valuable pilot tunnel for such characterization.

The potential for local blockage of the tunnel resulting from collapse of the tunnel crown has been addressed by incorporating an internal structural carrier pipe within the oversized tunnel section. The carrier pipe is constructed of rolled steel with an internal diameter of 1.8 m (6 feet) and wall thickness of 76 mm (3 inches). The internal diameter was established based on minimum post-earthquake flow requirements of 492,000 cubic meters per day (130mgd) (assuming that complete blockage occurs around the carrier pipe), and the wall thickness was designed to accommodate ground collapse loads. The pipe is lightly restrained by yieldable guide posts at either end, so that it is essentially free to rotate and shift as fault displacement occurs. As shown in Figures 5 and 6, the gap between the pipe walls and final tunnel lining is of sufficient dimension to preclude the tunnel shell from impinging on the carrier pipe, although movement of the tunnel shell will cause the pipe to slide and/or rotate into the post-earthquake position. The ability for the pipe to move in a largely unrestrained manner means that the pipe is effectively isolated from seismically induced loading conditions.

The discrete fault displacement depicted in Figure 6 is an idealization that results in conservative dimensions of the oversized tunnel section. While the primary fault offset may occur across a single well defined plane, it will more likely be distributed across many planes over a distance of several meters. A distributed faulting condition has the potential to damage a larger area of the tunnel lining and increase the potential

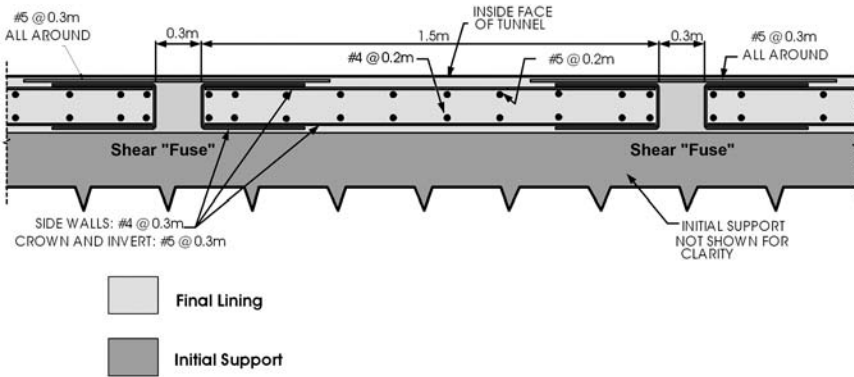

Figure 7. Shear fuses in the final concrete lining to create preferential fault displacements (longitudinal section at spring line)

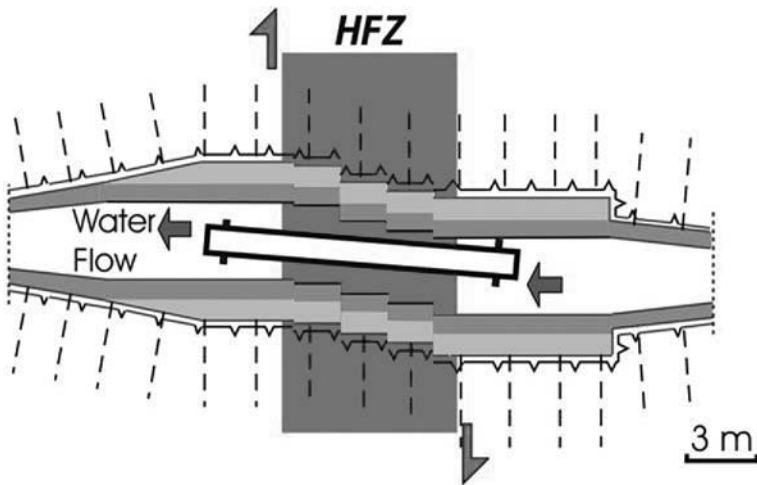

Figure 8. Plan view showing structural carrier pipe after 2.6 m (8.5 feet) of distributed fault offset (HFZ: Hayward Fault Zone)

for blockages around the carrier pipe. For this reason, it was desirable to create preferential areas for the fault displacement to occur through specific locations in the lining. As depicted in Figure 7, this is achieved by specifying 0.3 m (1 foot) gaps in the longitudinal lining reinforcement every 1.5 m (5 feet) throughout the tunnel interval subject to primary fault displacement.

The reinforcement gaps act as shear fuses, representing weak links in the lining and preferred paths for fault rupture. The goal of the shear fuse design is to promote breaks between adjacent lining disks, while sufficient reinforcing steel is provided between the shear fuses to minimize the potential for significant lining collapses. With this idealized behavior, the configuration of the oversized tunnel after the design fault displacement is as shown in Figure 8.

In addition to the primary fault movements, sections of the bypass tunnel with the potential for secondary fault offsets needed to be addressed by the design. This was accomplished by providing an oversized tunnel section with a nominal 0.7 m (2.25 foot) thick reinforced concrete liner. The flow cross section and liner will accommodate the secondary fault offsets by allowing the required flow to pass through the offset cross section, while minimizing debris that may enter the tunnel from the surrounding ground.

In addition to fault offsets within the Hayward Fault Zone, the new and existing tunnel liners will be subject to strong earthquake shaking. The original tunnel was supported initially with five-piece arch timber sets. The final lining consisted of a combination of reinforced and unreinforced concrete with a thickness of 100 to 150 mm (4 to 6 inches) over the timber sets. Only a small portion of the original lining was contact grouted and it is likely that some of the primary timber support has deteriorated. Gradual erosion of sedimentary formations along the alignment has also created voids behind the liner. These sections of lining are susceptible to damage from seismic shaking. A program of systematic contact grouting and structural repairs of existing liner defects were designed to improve ground/liner interaction during seismic shaking. The section of the existing tunnel that will be replaced by the new bypass tunnel is also scheduled to be abandoned by backfilling with cellular grout.

SUMMARY AND CONCLUSIONS

The design of the bypass tunnel to remain operational following a major fault event has sought to achieve reliability through redundancy. All the design measures are intended to mitigate the damaging effects of major earthquakes and provide the uninterrupted flow of water to EBMUD customers. Even with this stout approach, it must be anticipated that some damage will occur at the location of offsets. So long as the extent of damage does not preclude reliable operation of the Claremont Tunnel for a period of 60 to 90 days following the earthquake, the retrofit project will be judged a success. During this time period, EBMUD will undertake substantial repairs that are expected to be required for other components of their water supply and distribution system. Once these components are repaired or replaced, EBMUD will have the personnel and water resources necessary to take the Claremont Tunnel offline, perform an inspection, and make any repairs that are warranted.

The risks of building a tunnel across an earthquake fault were not clearly understood in the 1920s when the Claremont Tunnel was constructed across the Hayward Fault. A better understanding of fault behavior and risks identified by recent studies have emphasized the need to assure that this vital water lifeline is not lost. By implementing the innovative measures of the seismic retrofit, the Claremont Tunnel can continue to serve its customers in one of the most seismically active areas of the world.

ACKNOWLEDGMENTS

The authors wish to thank and acknowledge the support provided by the East Bay Municipal Utility District, the Colorado School of Mines and Jacobs Associates.

REFERENCES

- Brown, I.R., Brekke, T.L., Korbin, G.E. 1981. Behavior of the Bay Area Rapid Transit Tunnels through the Hayward Fault. Final Report to the U.S. Department of Transportation. Report No. UMTA-CA-06-0120-81-1.
- Diemer, D.M., Miller, M.L., Pratt, D.L., Lee, D.D. 1995. Seismic Evaluation and Improvement Program for a Major Water System. Lifeline Earthquake Engineering. Proceedings of the Fourth U.S. Conference. 304–311.
- Earthquake Engineering Research Institute. 1996. *Scenario for a Magnitude 7.0 Earthquake on the Hayward Fault*.
- Geomatrix Consultants. 2001. Preliminary Geologic Interpretive Report for the Claremont Tunnel Seismic Upgrade Project, Berkeley, California, Project Report.
- Geomatrix Consultants. 1993. Seismic Assessment of Tunnels, East Bay Municipal Utility District Water System Seismic Evaluation Program. Project Report.
- Kieffer, D.S., Caulfield, R.J., and Cain, B. 2001. Seismic Upgrades of the Claremont Tunnel. *2001 Rapid Excavation and Tunneling Proceedings*.
- Kieffer, D.S., Caulfield, R.J., and Tsztoo, D.F. 2004. Seismic Retrofit of the Claremont Tunnel. *EUROCK 2004 & 53rd Geomechanics Colloquium*.
- Working Group on California Earthquake Probabilities. 2003. *Earthquake Probabilities in the San Francisco Bay Region: 2002–2031–*. USGS Open-File Report 03-214.
- Young, Geo. J. 1929. Driving the Claremont Tunnel. *Engineering and Mining Journal*. 832–834.